

Description:

The PYROT Rotation Heating System (patent no: EP 0 905 442 B1) was developed for automatic incineration of all dry to moist wood fuels (remnant wood, pellets and forest woodchips to max. W35-40). The PYROT Rotation Heating System is characterised by high efficiencies and perfect incineration at all load levels. The PYROT Boiler Plant has been tested and approved in accordance with the latest quality criteria as per EN 303-5 Heating Boilers for solid fuels, CE-certification in accordance with European Machinery Directive with continuous quality inspection by the TÜV.

Max. forward flow temperature allowed: 100°C
 Max. operating pressure allowed: 3.0 bar
 Safety heat exchanger: Built into the boiler

How it functions:

- The feed auger conveys the material to be burned diagonally from below into the firing system. The holding devices for the burn-back sensor and the thermal extinguishing valve are situated on the conveyor pipe. Above the auger, there is a metering container with a light barrier to ascertain the level of the fuel isolating layer required according to TRD 414.
- The material to be burned is ignited automatically by an electric heat gun. The gasification of the fuel is carried out on a feed grate moved by a worm-gear motor. The ash falls in an ash bin below. An automatic de-ashing system is optional. The fire block is lined with highly refractory insulation and fired refractory concrete elements.
- The combustion gases rising from the fire block are swept up by the rotating secondary airflow brought to bear by the rotation blower and burned out completely in the round combustion chamber. The thermal energy from the combustion gases is transmitted to the boiler water in a horizontally positioned pipe-type heat exchanger. The boiler is heavily insulated, cased in an aesthetically pleasing fashion and provided with excellent access through the boiler door on the end side. On the rear side of the boiler there is a flange for an oil burner, which is closed by an insulated blank lid with an inspection window.
- A flue gas recirculation system reduces the temperature in the fire box while maintaining the highest possible degree of efficiency. This increases the service life of the uncooled refractory elements in the incineration zone. With the basic setting, the ratio of recirculated gas to fresh air is geared precisely to the material to be burned. A mechanical flow volume regulator provides a constant ratio of the quantity of recirculated gas to fresh air over the entire output range.
- The exhaust fan is specially designed for wood heating operation and is very quiet. The motor has a solid, heat-resistant design with a heat dissipation hub and is spring-supported. The fan casing on the intake port turns in infinitely variable fashion. The blow-out nozzle is round. Installation is possible on the top, side or rear of the exhaust gas collector.

Included in the delivery:

- Feed auger with isolating layer, incl. extinguishing valve with dirt trap, extinguishing water container with holding device
- Fire block with feed grate
- Automatic ignition device
- Boiler with rotation combustion chamber
- Set of displacement rods
- Flue gas recirculation system
- Exhaust fan
- Supplementary air device (draught controller); for installation in the exhaust pipe
- Accessories: counter-flange, incl. bolts, seals and cleaning device

Requirements on the chimney:

Installation of a supplementary air device (draught controller) if not possible in the fire tube (see Spec Sheet 6010-3).

ACCESSORIES for PYROT Rotation Heating System (Item KRT-...) at extra charge:

Designation	Item	Text	Dimensions	Use
Exhaust gas deduster 90 l	KRT-E...-1	6110	6110	Optional
De-ashing in bin, 240 l	KRT-A2-S	6120	6120	Optional (standard)
De-ashing in skip, 800 l	KRT-A8-S	6120	-	Variation for KRT-A2-S
De-ashing in base container	KRT-ES...-S	6120	6120	Variation for KRT-A2-S
Cleaning system, pneumatic	KRT-W...-S	6120	6120	Optional
Operating pressure of 6 bar allowed	KRT-P...	6200	-	Customised design from PYROT 220
Feed auger, two-stage	KRT-P2	6200	-	Optional (switchover: pellets to chips)
Insulation for recirculated flue gas line DN 80	KRT-RZ-IS1	6200	-	Advisable (or insulation by customer)
Insulation for recirculated flue gas line DN 125	KRT-RZ-IS2	6200	-	Advisable (or insulation by customer)
Reduced output:	KRT- VS-...		6200	optional (reduced charge)
Oil burner mounting bracket	KRT-OBW...-S	6300	6300	Optional
Ecotronic control system	ECO-...	6800	-	Required

Technical specs:

		PYROT Rotation Heating System					
Trade name		100	150	220	300	400	540
Item No:		KRT- 100	KRT- 150	KRT- 220	KRT- 300	KRT- 400	KRT- 540
Performance data							
Rated heat output	Q_N [kW]	100	150	220	300	400	540
Continuous output ¹⁾	Q_D [kW]	90	135	200	270	360	480
Minimum heat output ²⁾	Q_{min} [kW]	30	45	60	80	100	140
Efficiency in operation to be performed	[%]	90-92					
Maximum water content ³⁾	[%]	W 40					
Size of the chips ⁴⁾		G 30 / G 50 as per ÖNORM M7133					
Exhaust gas figures							
Mass flow rate Q_N ; W5; O ₂ 6%;	[g/s]	53.6	80.4	117.9	160.8	214.4	289.44
Volume flow Q_N ; W5; O ₂ 6%; 150 °C	[m ³ /s]	0.06	0.09	0.14	0.19	0.25	0.35
Mass flow rate Q_{W35} ; W35; O ₂ 8%;	[g/s]	71.3	106.9	156.9	213.9	285.2	385.1
Volume flow Q_{W35} ; W35; O ₂ 8%; 150 °C	[m ³ /s]	0.08	0.12	0.19	0.25	0.34	0.46
Average exhaust gas temperature at Q_N ⁵⁾	[°C]	160					
Average exhaust gas temperature at Q_{min} ⁵⁾	[°C]	130					
Chimney draught required	[Pa]	+0					
Electrical connections							
Electrical connections, total	[kW]	2.67	2.67	2.85	3.6	3.98	3.63
Ignition device	[kW]	1.6					
Exhaust gas fan	[kW]	0.55	0.55	0.55	0.75	1.1	1.1
Articulated head fan	[kW]	0.12					
Feed auger	[kW]	0.37	0.37	0.55	1.1	1.1	0.75
Grate drive unit	[kW]	0.03	0.03	0.03	0.03	0.06	0.06
Electric power consumption at Q_N	[kW]	0.85	1.032	1.108	1.521	1.868	1.753
Electric power consumption at Q_{min}	[kW]	0.28	0.355	0.369	0.434	0.480	0.460
Heating-relevant specs							
Volume on heating gas side	[ltr]	325	374	744	883	1340	1613
Volume of ash container for grate ash	[ltr]	26	32	45	55	75	91
Volume of ash container for exhaust gas de-duster	[ltr]	90					
Water-bearing resistance (Diff. 15 K)	[mbar]	38	33	76	42	29	56
Boiler water volume	[ltr]	395	432	794	903	1326	1510
Heating surface	[m ²]	8.28	10.78	16.04	20.72	28.76	39.36
Test pressure ⁶⁾	[bar]	5					
Maximum operating pressure ⁶⁾	[bar]	3					
Maximum boiler temperature	[°C]	100					
Minimum return temperature	[°C]	65					
Weights							
Weight of fire block	[kg]	432	477	581	641	778	937
Weight of boiler ⁷⁾	[kg]	1278	1451	2119	2441	3235	3671
Weight of displacement rods	[kg]	68	87	141	163	220	289
Weight of exhaust blower	[kg]	37	40	40	45	62	62
Weight of feed auger	[kg]	143	143	143	143	143	149
Total weight without water ⁸⁾	[kg]	1958	2198	3024	3433	4438	5108
Total weight with water ⁸⁾	[kg]	2353	2630	3818	4336	5764	6618

- 1) Continuous output: Output levelling out as base load boiler in continuous operation with pneumatic cleaning system (for track time, see Operating Instructions)
- 2) $Q \geq Q_{min}$: Operation with modulated control (Infinitely variable power control)
 $Q \leq Q_{min}$: Low load with ON Q_{min} / OFF (Stop-and-go mode)
- 3) Moist fuels: >W35 further limitations regarding output, degree of efficiency and control behaviour
- 4) Specification: See Spec Sheet 1010, Minimum Requirements for Wooden Fuels
- 5) Exhaust gas temperature: An increase is possible by removing the displacement rods ($Q_N + 30$ °C; $Q_{min} + 10$ °C)
 Other influences: Fuel, water content, ash content, pneumatic cleaning system yes/no; track time (number of operating hours without cleaning)
 Specifications for the start of the track time (toward the end of the track time there is an increase in the exhaust gas temperature by approx. 20 °C)
- 6) At extra charge: 7.8 bar test pressure; 6 bar operational pressure;
- 7) Weights: Incl. door and refractory concrete lining
- 8) Total weight: Incl. displacement rods

Dimensional drawing:

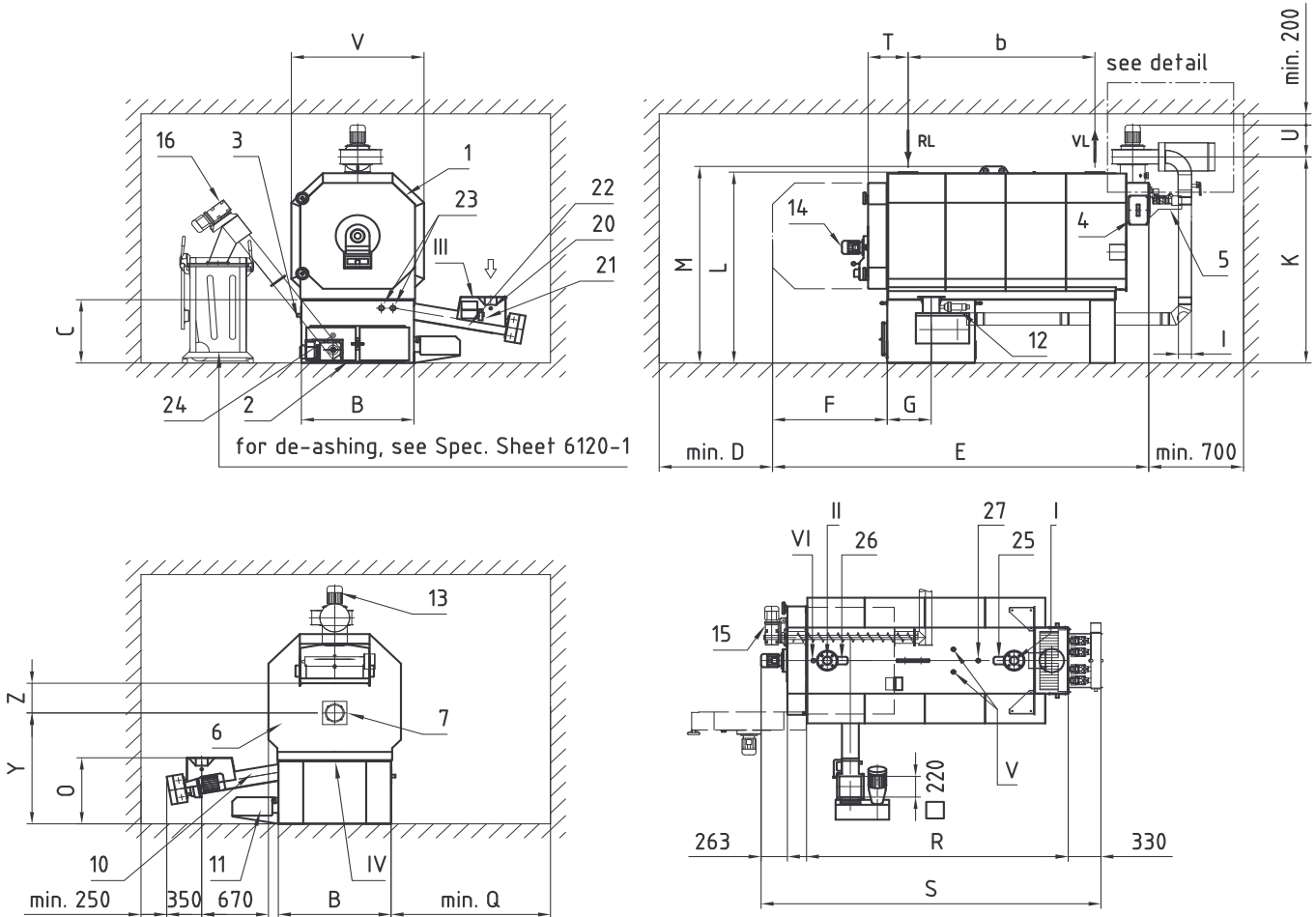

for de-ashing, see Spec. Sheet 6120-1

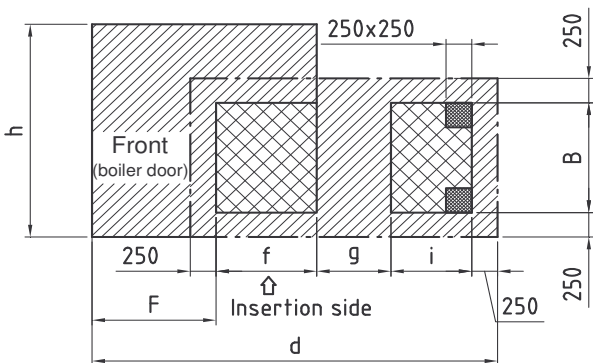

Boiler bearing surface



Bottom with heat-resistant design: extra



The surface of the floor has to be free of any pipes or installation lines !
The effects of heat would create a danger !

detail of how exhaust gas is conducted

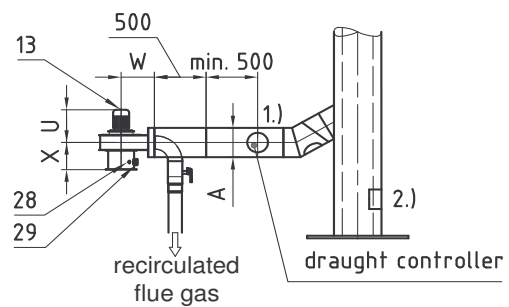

1.) Draught controller in the exhaust pipe:
included in scope of supply
Position: as close as possible to the chimney

2.) Draught controller in chimney, at bottom:
supplied by customer
Necessary: when not possible in exhaust pipe

Connections/dimensions:

PYRTEC [Item-Nr.]		KRT-100	KRT-150	KRT-220	KRT-300	KRT-400	KRT-540
Water connections PN 6 (see Spec Sheet 6960)							
I	Boiler forward flow	R 2" IG	R 2" IG	DN 80 PN6	DN 80 PN6	DN100 PN6	DN100 PN6
II	Boiler return flow	R 2" IG	R 2" IG	DN 80 PN6	DN 80 PN6	DN100 PN6	DN100 PN6
III	Connection for extinguishing water	R ¾"					
IV	Drain valve for boiler	R 1½" IG					
V	Safety heat exchanger	2 x R ½" AG	2 x R ½" AG	2 x R ½" AG	2 x R ½" AG	4 x R ½" AG	4 x R ½" AG
VI	Dipping shell for thermal run-off safety valve	R ½" IG					
Connection exhaust gas pipe Ø [mm]		A 200	250	250	300	350	350
Location of the connections [mm]		b 1291	1541	1525	1875	1800	2030
Dimensions of the foundations [mm]		d 2803	2850	3130	3613	3738	4103
	f	640	740	740	880	960	1095
	g	423	520	520	723	448	543
	h	1570	1570	2050	2050	2460	2460
	i	620	620	680	680	800	800
Dimensions of the boiler [mm]		B 870	870	1150	1150	1390	1390
	C	673	673	673	673	673	750
	D	1920	1920	2200	2200	2440	2440
	E	2870	3120	3424	3780	4004	4232
	F	870	870	1150	1150	1390	1390
	G	320	370	370	440	480	548
	I	DN 80	DN 80	DN 80	DN 125	DN 125	DN 125
	K	1891	1908	2168	2182	2457	2527
	L	1765	1765	2024	2024	2262	2332
	M	1825	1825	2084	2084	2422 ⁽¹⁾	2492 ⁽¹⁾
	O	700	700	700	700	700	742
	Q	700	700	900	900	1100	1100
	R	2000	2250	2274	2630	2614	2842
	S	2785	3035	3059	3415	3457	3685
	T	392	392	406	406	466	466
	U	345	358	358	352	375	375
	V	1050	1050	1330	1330	1570	1570
	W	292	292	292	323	323	442
	X	245	232	257	277	355	355
	Y	1093	1093	1179	1179	1219	1297
	Z		303	316	316	319	319

1) With PYROT 400/540: Suspension gear is detachable

Parts for maintenance			
1	Boiler door with rotation fan		
2	Ash doors for the grate ash (2 units)		
3	Maintenance cover for firing block		
4	Cleaning lid for exhaust gas collector		
5	Pneumatic cleaning system	Item KRT-W...-S	Spec Sheet 6120
6	Recirculated flue gas line, variable arrangement of line		
Accessories for oil burner			
7	Flange for burner mounting bracket; standard design: sealing cover with sight glass		
Electric drives & ignition			
10	Feed auger		
11	Drive for feed grate		
12	Ignition device		
13	Exhaust fan		
14	Articulated head fan		
15	De-ashing system for fire block	Item KRT-E-S	/ Spec Sheet 6120
16	De-ashing system for ascending conveyor auger	Item KRT-E-S	/ Spec Sheet 6120
Switches and sensors These items are part of the Ecotronic control system			
20	Light barrier for feed auger	Item PRT-...	/ Spec Sheet 6800
21	Limit switch for maintenance cover		
22	Temperature sensor for feed auger		
23	Light barrier for embers (2 units)		
24	Light barrier for de-ashing		
25	Boiler sensor		
26	Return flow sensor		
27	Temperature-limiting safety switch (STB)		
28	Exhaust gas sensor	Location:	Spec Sheet 6010
29	Lambda sensor with measuring transducer	Location:	Spec Sheet 6010